

ARC

STUD WELDING ACCESSORIES

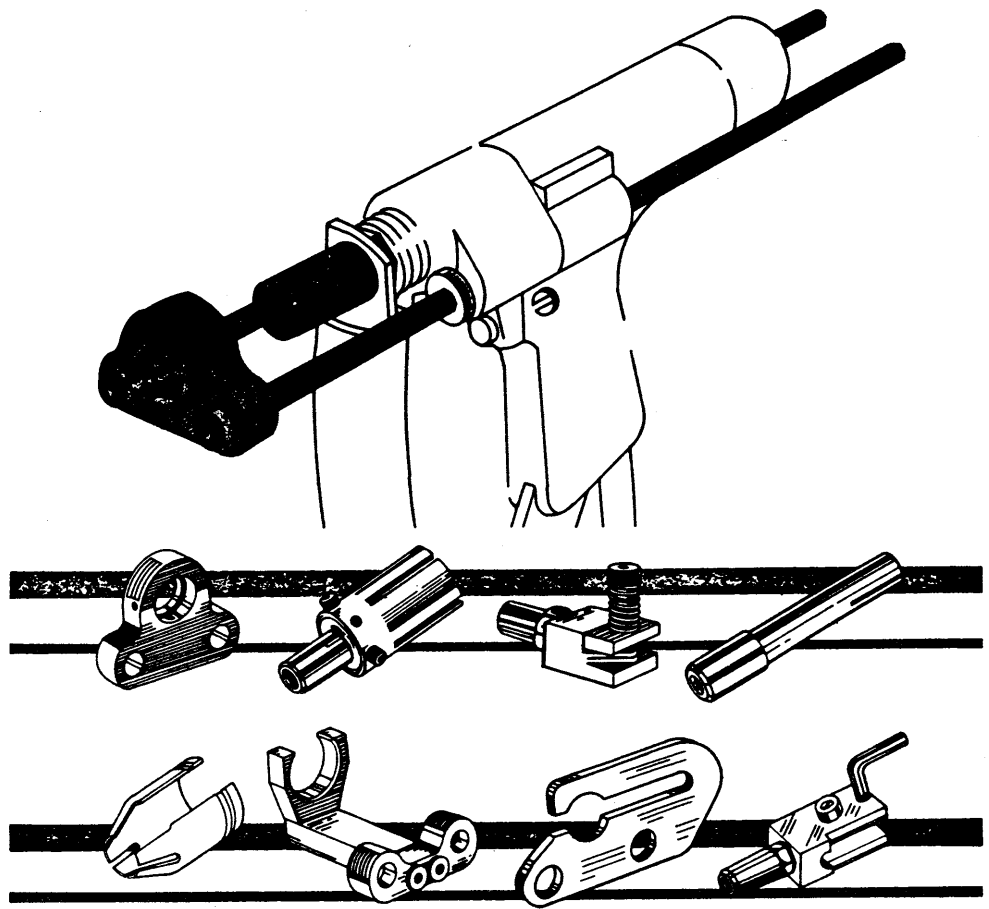

Specification Guide

INDUSTRIAL COMPONENTS-AR, LLC

Distributors of Stud Welded Fasteners, Equipment & Accessories

P.O. Box 22407, Little Rock, AR 72221

Bus: (501) 379-8760 Fax: (501) 379-8759 Toll Free: (877) 863-8955

STANDARD ADJUSTABLE ARC CHUCKS

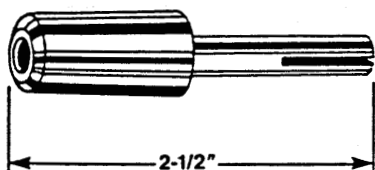

STUD DIA.	PART NO.
12 GA	015-510
1/8 or #5	015-511
10 GA or #6	015-512
#8	015-514

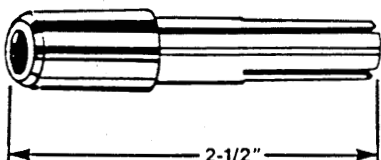

STUD DIA.	PART NO.
3/16 or #10	015-515
1/4	015-525
5/16	015-527
3/8	015-528
7/16	015-529
1/2 or (1/4 HCA)	015-530

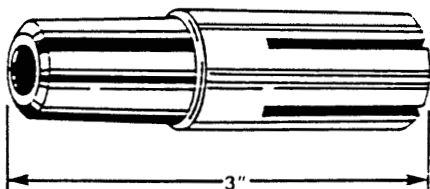

STUD DIA.	PART NO.
5/8	015-538
3/4 or (3/8 HCA)	036-625
7/8	043-013
1	015-543

NOTE: All chucks shown on this page also available in metric sizes.

LONG ADJUSTABLE ARC CHUCKS

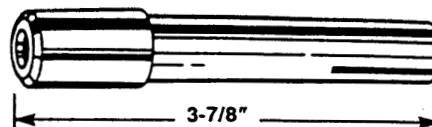

STUD DIA.	PART NO.
#8	043-051
3/16 or #10	033-792
1/4	022-862
5/16	022-863
3/8	018-929
7/16	022-864
1/2	020-161
5/8	043-047
3/4	043-048

EXTRA LONG ARC CHUCKS

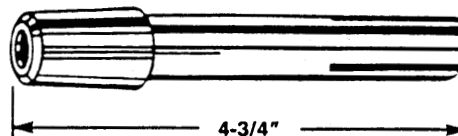

ADJUSTABLE	
STUD DIA.	PART NO.
#8	043-052
3/16 or #10	043-053
1/4	043-054
5/16	043-055
3/8	043-056
7/16	000-096
1/2	043-057
5/8	043-058
3/4	043-059
FIXED DEPTH (1/2")	
STUD DIA.	PART NO.
1/4	043-114
5/16	043-115
3/8	043-116
7/16	043-117
1/2	043-118
5/8	000-060
3/4	043-120

HEADED CONCRETE ANCHOR & SHEAR CONNECTOR CHUCKS

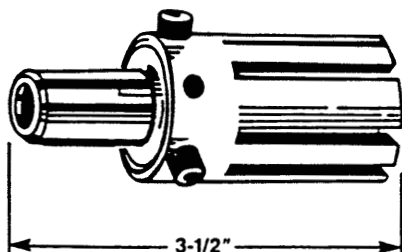

CHUCK DIA.	PART NO.
1" ASS'Y. (or 1/2 HCA)	036-615
Body	043-108
Tines	044-025
Adj. Stop	019-559

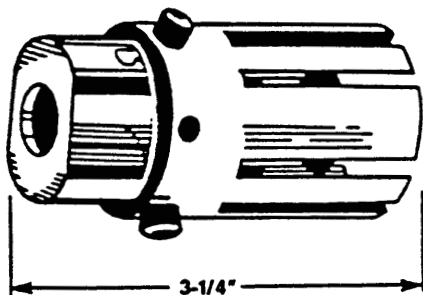

STUD SIZE	5/8 HCA, or 3/4 SC	7/8 SC
CHUCK DIA.	1-1/4"	1-3/8"
ASS'Y.	043-134	036-627
Body	043-135	043-137
Tines	043-136	043-110
Adj. Stop	037-547	037-547
Tine Mtg. Screw	004-930	
Stop Lock Screw	016-753	
Tapered Adaptor *	044-085	
Adaptor Jam Nut *	034-162	

* optional (not shown)

RECTANGULAR CHUCKS

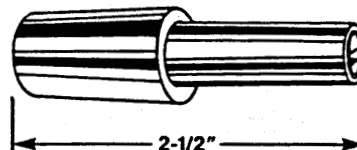

STUD SIZE	PART NO.
1/8 x 3/8 ASS'Y.	033-790
Body	043-022
Insert	033-788
Insert Screw	019-407
Lock Washer	036-130

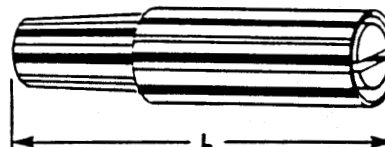

STUD SIZE	1/8 X 5/8	1/8 X 7/8
L:	3"	3-3/4"
ASS'Y.	033-791	000-197
Body	043-023	011-456
Insert	033-789	000-198
Insert Screw	018-654	018-779
Lock Washer	036-130	009-937

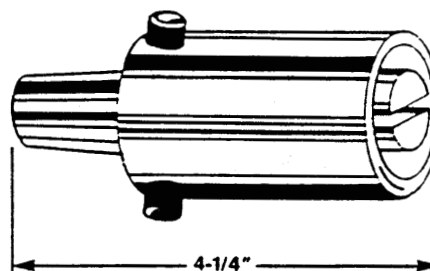

STUD SIZE	PART NO.
1/4 x 1-1/4 ASS'Y.	021-371
Body	043-041
Insert	043-042
Insert Screw	037-540
Lock Washer	036-130
Sleeve	043-043
Sleeve Screw	016-774

SPECIAL RECTANGULAR CHUCKS

STUD SIZE	PART NO.
1/8 x 1/4 ASS'Y.	003-447
1/8 x 1" ASS'Y.	043-028
3/16 x 3/4 ASS'Y.	043-026
3/16 x 1" ASS'Y.	043-030
1/4 x 3/4 ASS'Y.	029-431

BENT STUD CHUCKS – STD. COMPONENTS

ITEM	PART NO.
Clamp Screw	043-197
Ball Plunger	043-196
Hex Nut	004-422
Shoulder Screw	037-548
Spring	043-219
Tapered Adaptor	044-085
Adaptor Jam Nut	034-162

The following "Bent Stud Chucks" are illustrated for reference purposes. Bent studs may vary in bend angle and/or bend radius for different applications. Therefore it is necessary to specify the part to be welded and the application to ensure receiving the correct chuck. The components in the chart above are standard replacement parts for these Bent Stud Chucks.

90° BENT STUD CHUCK

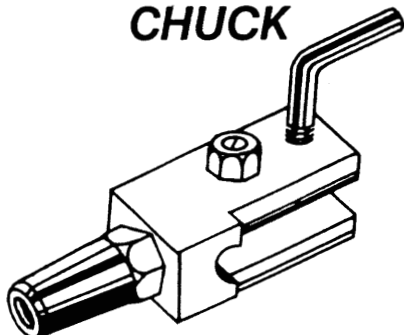

45° BENT STUD CHUCK

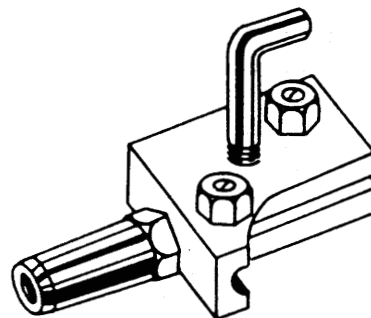

EYE BOLT CHUCK

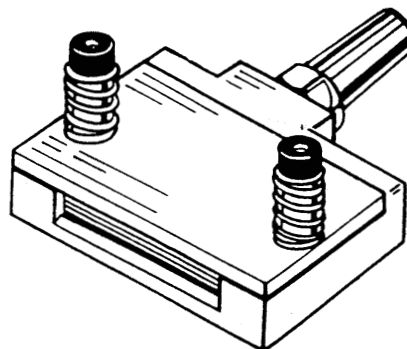

"J" BOLT CHUCK

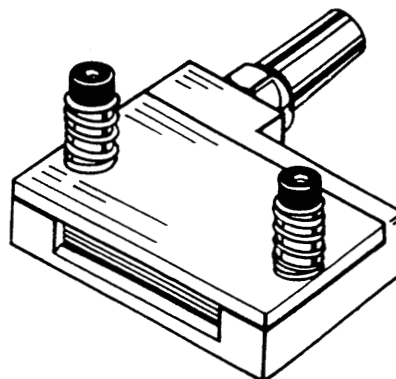

MISCELLANEOUS CHUCKS

ITEM	PART NO.
Railroad Spacer Stud Chuck	043-111
Metric 3mm	025-729
5mm	025-731
6mm	017-105
8mm	017-106
10mm	017-107
12mm	017-108

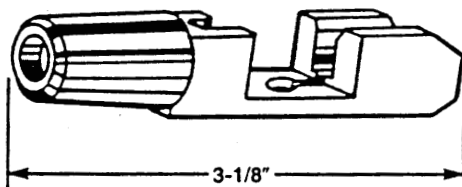
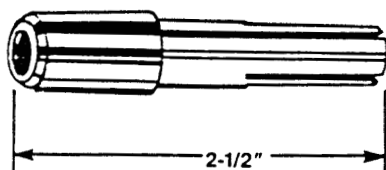
INSUL-TWIST CHUCKS

FOR STUDS	PART NO.
Shorter than 6-1/2"	015-525
6-1/2" or Longer	003-447

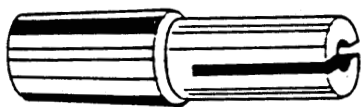
ULTRA-LOK CHUCKS

FOR STUDS	PART NO.
Shorter than 3"	033-797
3" or Longer	033-796

(RA-Y) CHUCKS

These chucks are used for stud welding "Y" style refractory anchors with an 80° bend angle, such as Positgrip, Bullhorn, and Y-Anchors.

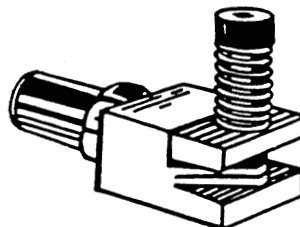

ANCHOR DIA.	3/16"	1/4"	5/16"
ASS'Y.	033-794	033-341	033-340
Body	043-091	043-093	043-089
Contact Plate	043-092		043-087
Shoulder Screw	037-549		016-872
Spring	033-793		043-090
Washer	004-417		N/A
Tapered Adaptor	044-085		N/A
Adaptor Jam Nut	034-162		N/A

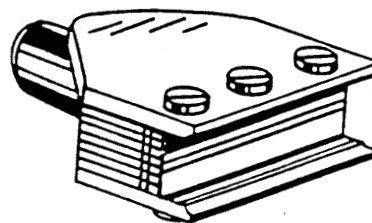
"T"-PLATE CHUCK

"T"-PLATE SIZE	PART NO.
1/4 Thick x 7/8 Wide x "L" ASS'Y.	043-207
Body	043-208
Bottom Plate	043-209
Top Plate	043-210
Spacer	043-211
Mtg. Screw	018-220
Plunger	043-212
Plunger Screw	034-477
Tapered Adaptor	044-085
Adaptor Jam Nut	034-162

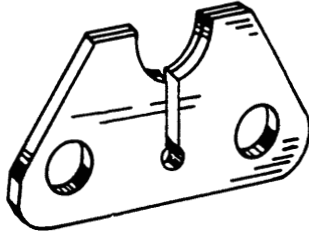
ARC STUD WELDING ACCESSORIES**FERRULE FOOTPLATES****STANDARD FERRULE
FOOTPLATE**

STUD DIA.	GRIP DIA.	PART NO.
1/4	.380	037-164
5/16	.445	039-127
3/8	.505	039-121
7/16	.585	039-122
1/2	.650	039-123
5/8	.785	039-124
3/4	1.030	039-125
7/8	1.203	039-126

**(RA-Y) FERRULE
FOOTPLATE**

This ferrule footplate is used for stud welding "Y" style refractory anchors such as Positgrip, Bullhorn, or Y-Anchors.

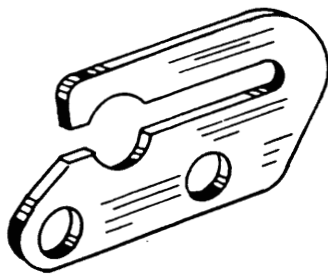

STUD DIA.	GRIP DIA.	PART NO.
3/16 or 1/4	.785	037-165
5/16	1.030	048-704

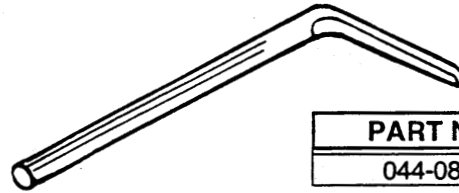
CHUCK EJECTOR KEY

PART NO.

044-088

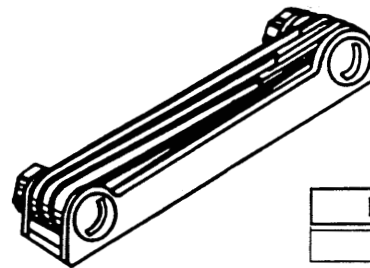
ALLEN WRENCH SET

PART NO.

023-581

**MISCELLANEOUS
(NOT SHOWN)**

ITEM	PART NO.
Arc Gun Screw Kit	039-050
Cap Setting Tool (for AG Caps)	033-786
Spanner Nut Wrench	026-773

ARC STUD WELDING ACCESSORIES

GUN SET-UP

The ARC stud welding accessories shown in this booklet allow the ARC Gun to be "set up" to weld a wide variety of different types and sizes of ARC studs with a minimal amount of time required for changeover. Several typical set-ups are shown below for reference. Final adjustments necessary for the gun and welder are explained in the welder operation manual.

TOOLS REQUIRED

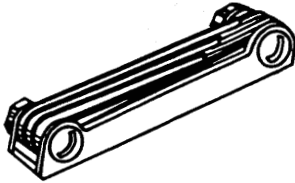

Allen Wrench Set

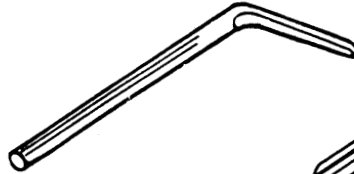

Chuck Ejector Key

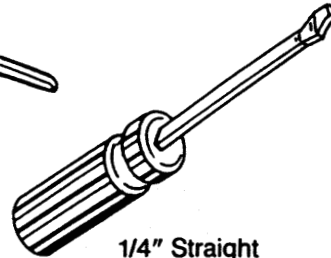

1/4" Straight Blade Screwdriver

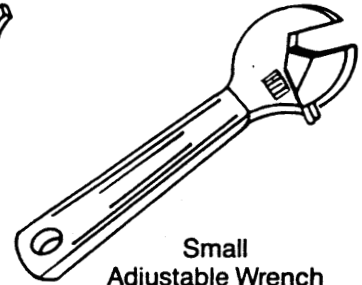

Small Adjustable Wrench

SET-UPS

STANDARD

For threaded & non-threaded studs.

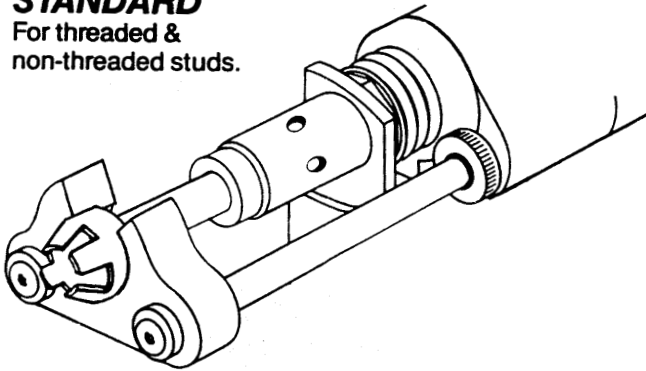

BENT STUDS

For 90° bent studs of all types.

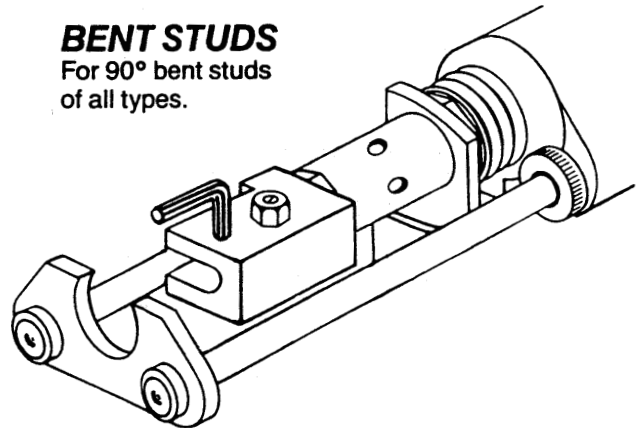

REFRACTORY ANCHOR

For bullhorn & "Y"-refractory anchors.

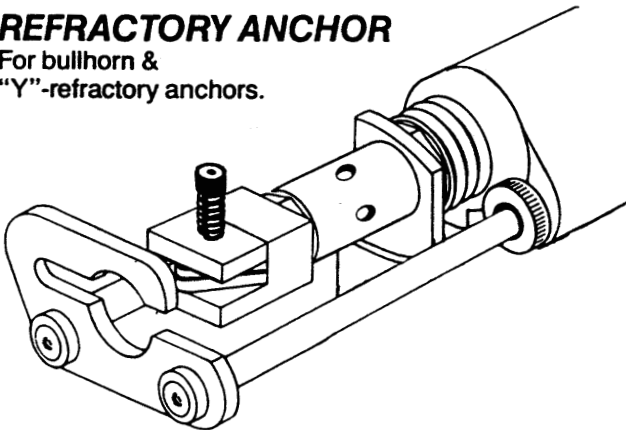

WELD THRU DECK

For welding headed anchors thru corrugated decking.

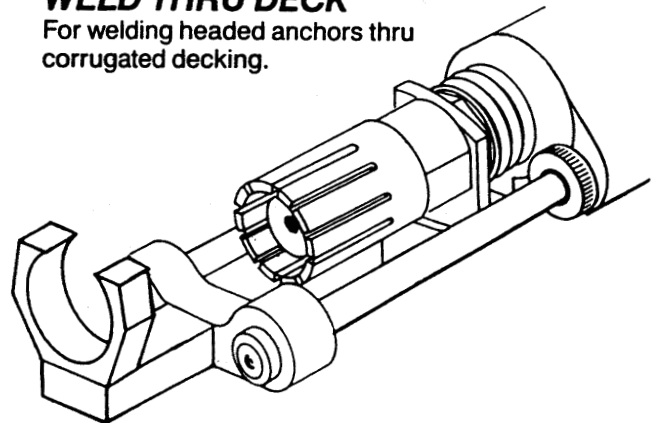

STANDARD FERRULE GRIPS (1" LONG)

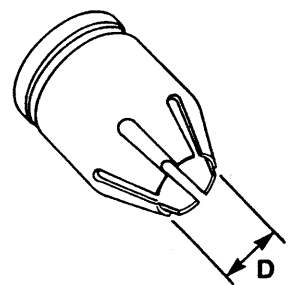

FULL BASE STUD SIZE	GRIP DIA. (D)	FOOT REQUIRED	PART NO.
10 GA or #6	.281	Small	000-297
#8	.291	Small	039-138
3/16 or #10	.305	Small	000-284
1/4	.380	Small	000-285
5/16	.445	Small	000-286
3/8	.505	Small	000-287
7/16	.585	Small	000-288
1/2	.650	Small	044-077
5/8	.785	Medium	048-310
3/4	1.030	Medium	044-076
7/8	1.203	Large	044-075
1"	1.406	Large	000-294
1/8 x 5/8 Rect.	.921	Medium	037-157

SPLIT FERRULE GRIPS (1" LONG)

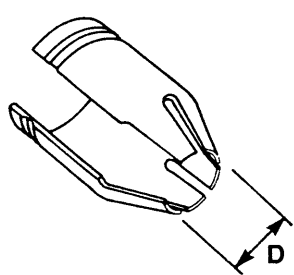

FULL BASE STUD SIZE	GRIP DIA. (D)	FOOT REQUIRED	PART NO.
10 GA or #6	.281	Small	000-316
3/16 or #10	.305	Small	000-317
1/4	.380	Small	000-303
5/16	.445	Small	000-304
3/8	.505	Small	000-305
7/16	.585	Small	000-306
1/2	.650	Small	044-071
5/8	.785	Medium	000-308
3/4	1.030	Medium	044-073
7/8	1.203	Large	044-207
1"	1.406	Large	000-301
1/8 x 5/8 Rect.	.921	Medium	000-309

LONG SPLIT FERRULE GRIPS (2" LONG)

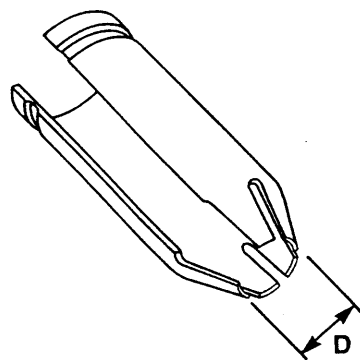

FULL BASE STUD SIZE	GRIP DIA. (D)	FOOT REQUIRED	PART NO.
1/4	.380	Small	039-143
5/16	.445	Small	039-144
3/8	.505	Small	039-145
7/16	.585	Small	039-146
1/2	.650	Small	039-147
5/8	.785	Medium	039-148
3/4	1.030	Medium	039-149

SHEAR CONNECTOR FERRULE GRIP

(For use with shear connector bipod foot)

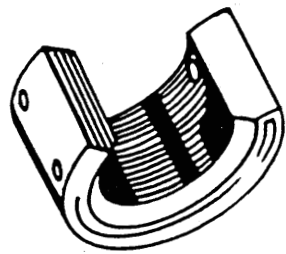

STUD DIA.	GRIP DIA.	PART NO.
1/2	.680	039-174
5/8	.815	039-175
3/4	1.060	039-176
7/8	1.240	039-177

WELD THRU DECK FERRULE GRIP

(For use with weld thru deck extension foot)

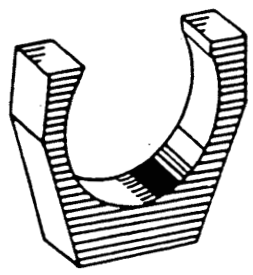

STUD DIA.	GRIP DIA.	PART NO.
3/4	1.060	048-399
7/8*	1.240	048-398
Mtg. Screws		016-774

*This is also used for WTD-750 Ferrule.

FERRULE TUBE & FERRULE TUBE BUSHINGS

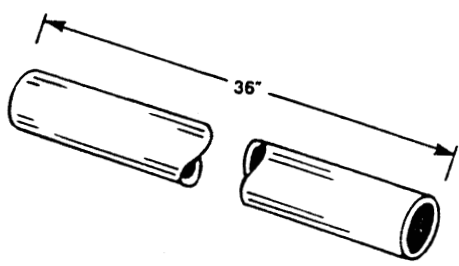
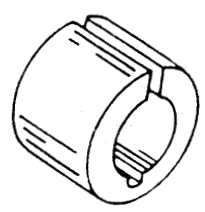

STUD DIA.	BUSHING PART NO.	TUBE PART NO.	FOOT REQUIRED
10 GA	039-154	049-080	Small
3/16	039-155	049-081	Small
1/4	039-156	049-082	Small
5/16	039-157	049-083	Small
3/8	039-158	049-084	Small
7/16	039-159	049-085	Small
1/2	039-160	049-086	Small
5/8	039-161	049-087	Medium
3/4	039-162	039-153	Large

BALL STUD CHUCK

(Adjustable, replaceable tines)

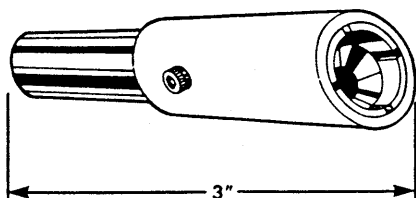

STUD DIA.	3/8"	1/2"	5/8"
ASS'Y.	019-496	019-472	020-885
Body	019-492	019-468	020-661
Adj. Stop	019-495	019-471	020-887
Tines	019-493	019-469	020-662
Sleeve	019-494	019-470	020-886
Tines Screw	009-899		

MALE CHUCKS

(For short tapped studs)

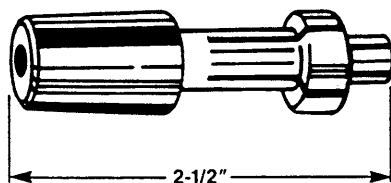

TAP SIZE	PART NO.
#8	043-063
#10	043-060
1/4	015-545
5/16	015-546
3/8	015-547
7/16	043-064
1/2	015-549
5/8	043-061
3/4	043-062

STANDARD ADJUSTABLE LEGS

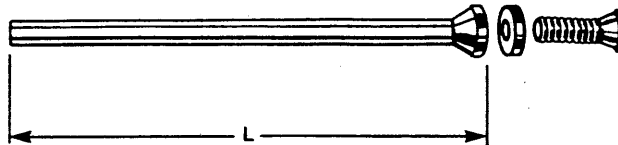

LENGTH	PART NO.
7"	000-355
9"	039-926
14"	032-062
18"	000-366
23"	000-363
27"	039-930
32"	039-931
36"	000-367
Leg Washer	039-935
Leg Screw (STD)	018-455
Leg Screw (Short-for Footplates)	017-280

STANDARD ADJUSTABLE FOOT

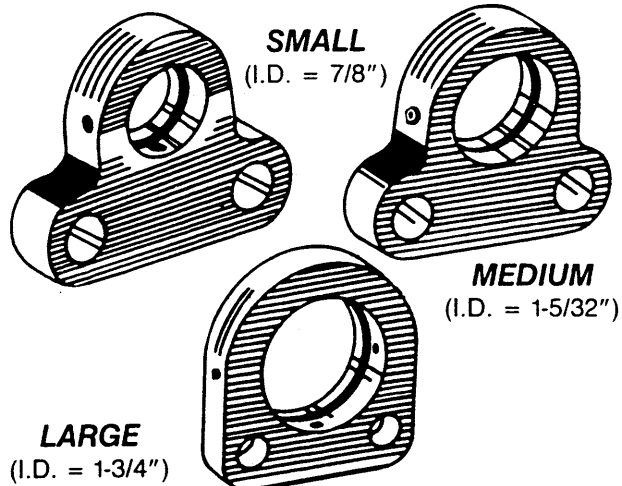

SIZE	STUD RANGE	PART NO.
Small	Up To 1/2"	037-001
Medium	5/8"-3/4"	037-162
Large	7/8" And Up	037-163

ARC STUD WELDING ACCESSORIES **FEET**

SPLIT ADJUSTABLE FOOT

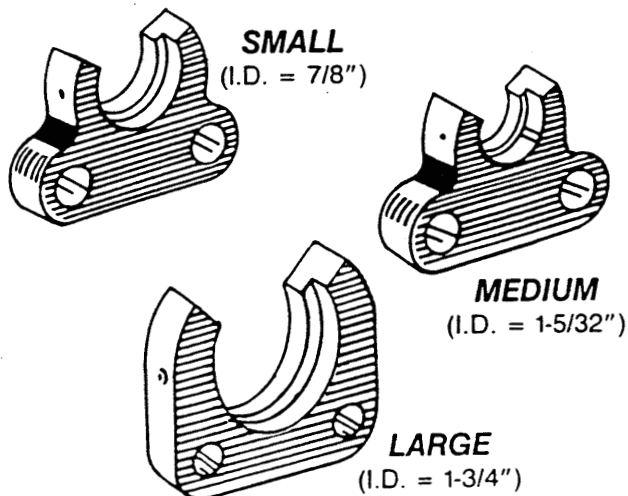

SIZE	STUD RANGE	PART NO.
Small	Up To 1/2"	037-161
Medium	5/8"-3/4"	037-160
Large	7/8" And Up	044-064

BIPOD FOOT

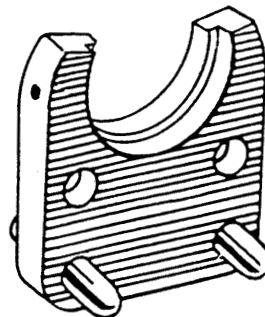

SIZE	PART NO.
Std. Small Ass'y.	039-091
Std. Medium Ass'y.	039-093
Split Small Ass'y.	039-095
Split Medium Ass'y.	039-097
Shear Conn. Ass'y.	039-099
Leg	039-090
Nut	004-425

GAS ADAPTOR FOOT

(For welding aluminum studs)

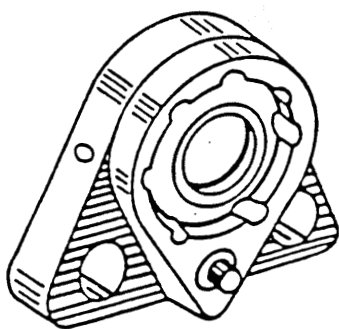

ACCESSORIES	PART NO.
Gas Foot Assembly	040-322
Regulator	040-311
15' Gas Hose	040-310

WELD THRU DECK EXTENSION FOOT

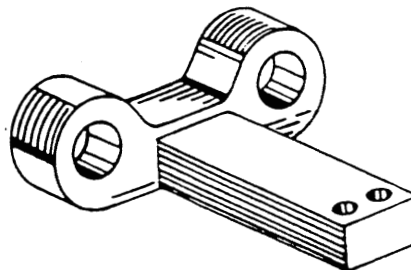

ITEM	PART NO.
ASSY.	044-062
Foot	039-984
Extension	039-985
Screws	012-035

ARC ACCESSORY REQUIREMENTS

STUD	Type	Dia.	CHUCK p/n	FOOT Size	FERRULE GRIP p/n		p/n	FERRULE			
					(Closed)	(Split)		Code	Neck Dia.		
ST		1/4	015-525	Small	000-285	000-303	009-664	P 250	.380		
		5/16	015-527	Small	000-286	000-304	009-665	P 312	.445		
		3/8	015-528	Small	000-287	000-305	009-666	P 375	.505		
		7/16	015-529	Small	000-288	000-306	009-667	P 437	.585		
		1/2	015-530	Small	044-077	044-071	009-668	P 500	.650		
		5/8	015-538	Medium	048-310	000-308	009-669	P 625	.785		
		3/4	036-625	Medium	044-076	044-073	009-670	P 750	1.030		
		7/8	043-013	Large	044-075	044-207	009-671	P 875	1.203		
		1"	036-615	Large	000-294	000-301	009-672	P 1000	1.406		
		FT		#10	015-515	Small	000-284	000-317	009-687	FT 187	.305
1/4	015-525			Small	000-285	000-303	009-688	F 250	.380		
5/16	015-527			Small	000-286	000-304	009-689	F 312	.445		
3/8	015-528			Small	000-287	000-305	048-303	FT 375	.505		
7/16	015-529			Small	000-288	000-306	009-691	F 437	.585		
1/2	015-530			Small	044-077	044-071	029-215	FT 500	.650		
5/8	015-538			Medium	048-310	000-308	009-693	F 625	.785		
3/4	036-625			Medium	044-076	044-073	009-694	F 750	1.030		
7/8	043-013			Large	044-075	044-207	009-695	F 875	1.203		
1"	036-615			Large	000-294	000-301	009-696	F 1000	1.406		
FB		3/16	015-515	Small	000-284	000-317	009-710	F 187	.305		
		1/4	015-525	Small	000-285	000-303	009-688	F 250	.380		
		5/16	015-527	Small	000-286	000-304	009-689	F 312	.445		
		3/8	015-528	Small	000-287	000-305	009-690	F 375	.505		
		7/16	015-529	Small	000-288	000-306	009-691	F 437	.585		
		1/2	015-530	Small	044-077	044-071	009-692	F 500	.650		
		5/8	015-538	Medium	048-310	000-308	009-693	F 625	.785		
		3/4	036-625	Medium	044-076	044-073	009-694	F 750	1.030		
		7/8	043-013	Large	044-075	044-207	009-695	F 875	1.203		
		1"	036-615	Large	000-294	000-301	009-696	F 1000	1.406		
LRB		1/4	015-525	Small	000-284	000-317	009-710	FS 250	.305		
		5/16	015-527	Small	000-285	000-303	009-688	FS 312	.380		
		3/8	015-528	Small	000-287	000-305	009-615	FS 375	.505		
		7/16	015-529	Small	000-288	000-306	009-616	FS 437	.585		
		1/2	015-530	Small	044-077	044-071	009-617	FS 500	.650		
		5/8	015-538	Medium	048-310	000-308	009-618	FS 625	.785		
		3/4	036-625	Medium	037-157	000-309	009-619	FS 750	.921		
		SRB		1/4	015-525	Small	000-285	000-303	009-679	TB 250	.380
				5/16	015-527	Small	000-286	000-304	009-680	RB 312	.445
				3/8	015-528	Small	000-287	000-305	009-681	RB 375	.505
1/2	015-530			Small	044-077	044-071	009-683	RB 500	.650		
5/8	015-538			Medium	048-310	000-308	009-684	TB 625	.785		
3/4	036-625			Medium	037-157	000-309	009-685	TB 750	.921		

STUD	Type	Dia.	CHUCK p/n	FOOT Size	FERRULE GRIP p/n		p/n	Code	Neck Dia.
					(Closed)	(Split)			
COL		1/4	015-525	Medium	048-310	000-308	009-712	C 250	.785
		5/16	015-527	Medium	048-310	000-308	009-713	C 312	.785
		3/8	015-528	Medium	048-310	000-308	009-714	C 375	.785
		1/2	015-530	Medium	044-076	044-073	009-694	C 500	1.030
R		1/8 x 3/8	033-790	Small	000-287	000-305	009-623	R 375	.505
		1/8 x 5/8	033-791	Medium	037-157	000-309	009-643	R 625	.921
		1/8 x 7/8	000-197	Medium	037-157	000-309	009-643	R 625	.921
		1/4x1-1/4	021-371	021-836 ¹	—	—	009-628	R 1250	1.562
DCA		1/4	015-525	Small	—	000-303	009-688	F 250	.380
		3/8	015-528	Small	—	000-305	009-690	F 375	.505
		1/2	015-530	Small	—	044-071	009-692	F 500	.650
		5/8	015-538	Medium	—	000-308	009-693	F 625	.785
HCA		1/4	015-530	Small	—	000-303	009-688	F 250	.380
		3/8	036-625	Small	—	000-305	009-690	F 375	.505
		1/2	036-615	Small	—	044-071	009-692	F 500	.650
		5/8	043-134	Medium	—	000-308	009-693	F 625	.785
HCA- Inside Angle		1/4	015-530	Small	.125 R ⁴	039-144 ²	036-389	F250-IA12	.445
		3/8	036-625	Small	.187 R ⁴	039-145 ²	009-633	F375-IA18	.505
		1/2	036-615	Small	.250 R ⁴	039-145 ²	049-686	F375-IA25	.505
		5/8	043-134	Medium	.375 R ⁴	039-147 ²	009-632	F500-IA25	.650
SC-		3/4	043-134	Medium	.375 R ⁴	039-147 ²	038-391	F500-IA37	.650
		3/4	043-134	Medium	.375 R ⁴	039-148 ²	009-644	F625-IA37	.785
		3/4	043-134	Medium	.625 R ⁴	039-149 ²	009-645	F750-IA62	1.030
		3/4	043-134	Medium	.375 R ⁴	039-149 ²	049-697	F750-IA37	1.030
HCA- Outside Angle		3/8	036-625	Small	—	000-305	009-636	F 375-OA	.505
		1/2	036-615	Small	—	044-071	009-647	F 500-OA	.650
		5/8	043-134	Medium	—	000-308	009-648	F 625-OA	.785
SC-Std.		3/4	043-134	044-062 ³	—	048-399 ³	009-694	F 750	1.030
		7/8	036-627	044-062 ³	—	048-398 ³	009-695	F 875	1.203
SC-WTD		3/4	043-134	044-062 ³	—	048-398 ³	009-704	WTD 750	1.203
		IT to 6-1/2 L longer	015-525	Small	000-287	000-305	009-661	R 250	.505
BH		(3/16)	033-794	037-165 ¹	—	—	009-658	RA 187	.785
		(3/16)	033-794	037-165 ¹	—	—	009-658	RA 187	.785
P-Grip "Y"		(1/4)	033-341	037-165 ¹	—	—	009-651	RA 250	.785
		(5/16)	033-340	048-704 ¹	—	—	003-891	RA 312	1.045

NOTES: 1) This is a ferrule footplate.
 2) This ferrule grip is 2" long.
 3) This extension foot and ferrule grip are used as an assembly.
 4) This represents fillet radius inside angle iron.

